

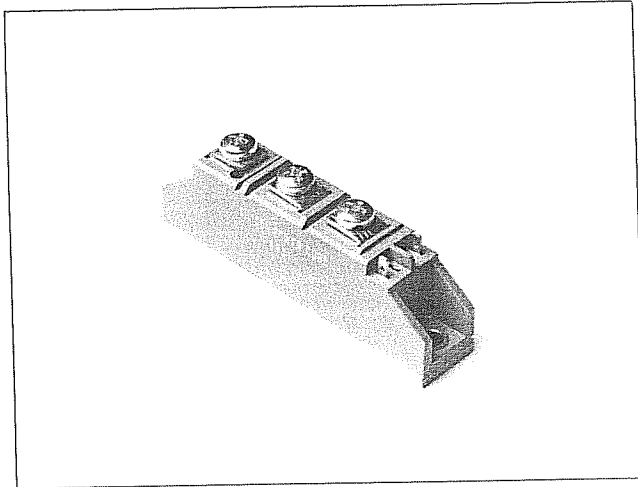

**SILICON
POWER
CUBE**

**F-18 SERIES
25A-90A POWER
SCR/DIODE MODULES**



FEATURES

- Thirteen standard module configurations available
- Standard voltages of 200 volts to 1400 volts.
Average device current output ratings of 25 amps to 90 amps
- Ultra-high surge current capabilities
- SPC's unitized power hybrid technology provides highly efficient thermal management for greatly extended cyclic life
- UL Component Recognition
- 2500VAC RMS terminal-to-base isolation
- All units are 100% tested at both 25° C and 125° C temperature levels — for assured quality

PARAMETER	SYM.	UNITS	SPECIFICATION LIMITS				CONDITIONS
			25	40	55	90	
Average Output Current per Device	I_o	A	25	40	55	90	$T_c = 85^\circ\text{C}$
One-Cycle Surge Current (Peak)	I_{TSM}	A	400	1000	1500	1950	$T_c = 125^\circ\text{C}$ Non-Replicative
I^2t for Fusing (Max.)	I^2t	A^2S	670	4150	9340	15,800	
Rate-of-Rise of On-State Current (Max.)	di/dt	$A/\mu S$	100				Max V_{DRM} , Peak On-State Current = $9 \times I_o$ (Avg.)
Rate-of-Rise of Off-State Voltage (Max.)	dv/dt	$V/\mu S$	200*				Exponential Rise to 80% V_{DRM} , Gate Open Circuit, $T_c = 125^\circ\text{C}$
Reverse Blocking Voltage (Max.)	V_{RRM}	V	200 - 1400*				$T_J = 125^\circ\text{C}$
Leakage Current (Max.)	I_{RM}	mA	20				$T_J = 125^\circ\text{C}$ at Rated Voltage
Isolation Voltage (Min.)	V_{ISOL}	Vrms	2500				Any Terminal-to-Base
Junction Operating and Storage Temperature Range	T_J & T_{STG}	$^\circ\text{C}$	- 40 to + 125				
Thermal Resistance (Case-to-Sink)	$R\theta_{c-s}$	$^\circ\text{C/W}$	0.1				With Thermal Grease
Thermal Resistance (Junction-to-Case)	$R\theta_{j-c}$	$^\circ\text{C/W}$	0.67	0.37	0.20	0.18	Per Module
Forward Gate Current (Peak)	I_{FGM}	A	10				$T_c = 25^\circ\text{C}$
Gate Current Required to Fire all Devices (Max.)	I_{GT}	mA	150				
Forward Gate Voltage (Peak)	V_{FGM}	V	30				
Reverse Gate Voltage (Peak)	V_{RGM}	V	5				
Gate Voltage Required to Fire all Devices (Max.)	V_{GT}	V	3				$T_c = 25^\circ\text{C}$
Latching Current (Max.)	I_L	mA	500				
Holding Current (Max.)	I_H	mA	300				
Gate Power (Peak)	P_{GM}	W	50				10 μS Pulse
Case Style						F18	See following page for circuit configurations and outline dimensions

* Higher values are available. Consult Factory.

PART NUMBER DESIGNATION CODE

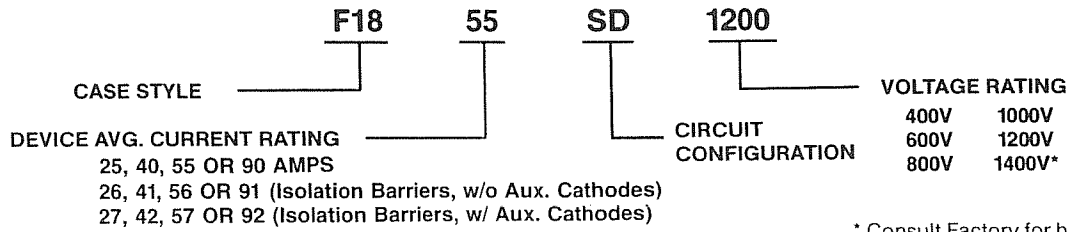

CIRCUIT CONFIGURATIONS

Important: Circuits marked with "*" reflect change in terminal position.
Circuits marked with "+" reflect change in gate terminals orientation.

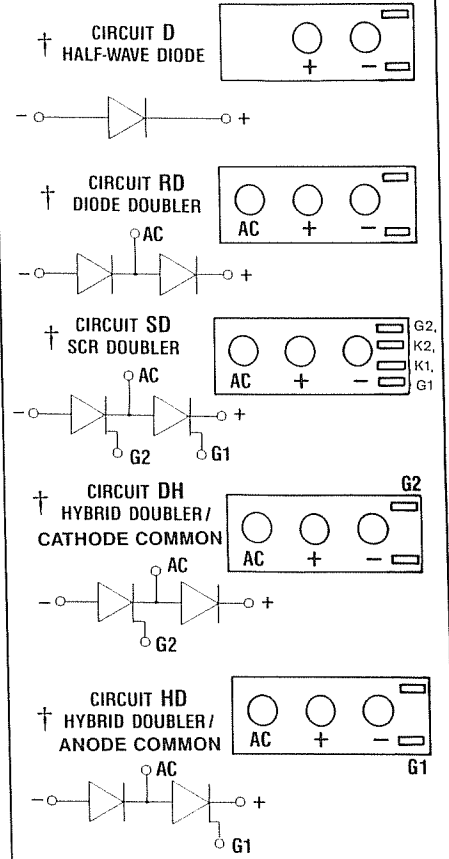
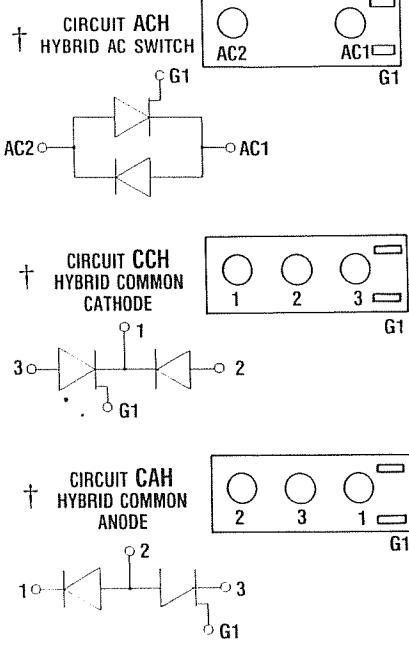
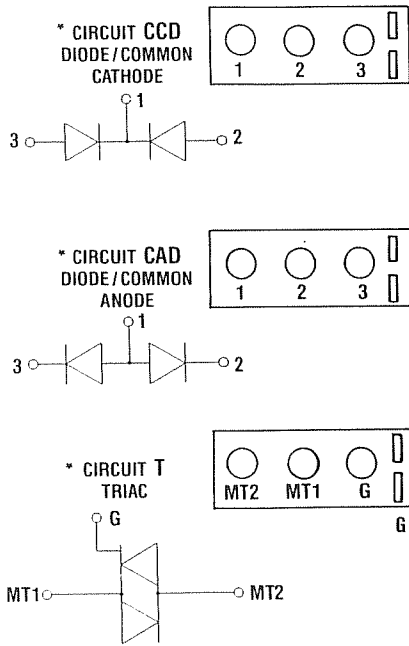

OUTLINE / MOUNTING DIMENSIONS

DIM.	INCHES		MILLIMETERS	
	MAX.	MIN.	MAX.	MIN.
A	3.630	3.610	92.2	91.7
B	0.797	0.777	20.2	19.7
D	0.797	0.777	20.2	19.7
E	0.520	0.480	13.2	12.2
F	1.205	1.160	30.6	29.5
G	1.100	1.070	27.9	27.2
H	3.155	3.145	80.1	79.9
J	0.130	0.120	3.3	3.0
K	0.260	0.240	6.6	6.1
L	0.380	0.370	9.7	9.4
M	0.249	0.239	6.3	6.1

MOUNTING TORQUE REQUIRED:
(A) Mounting Screws 20 in.-lbs.
(B) Terminal Studs (Screws supplied) . 30 in.-lbs.
Unmounted

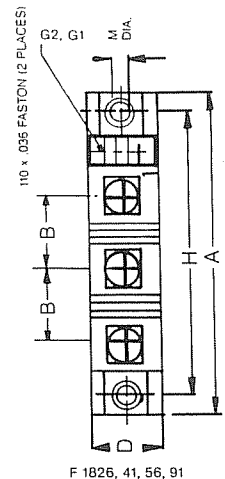
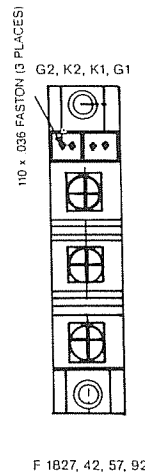
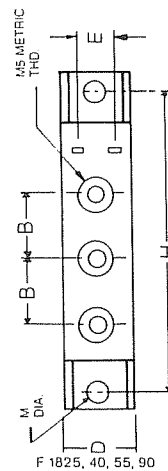
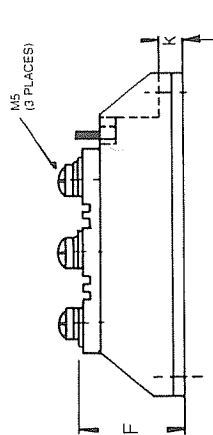

F18 SERIES MAXIMUM ALLOWABLE AVG. CURRENT PER DEVICE VS. BASE PLATE TEMPERATURE

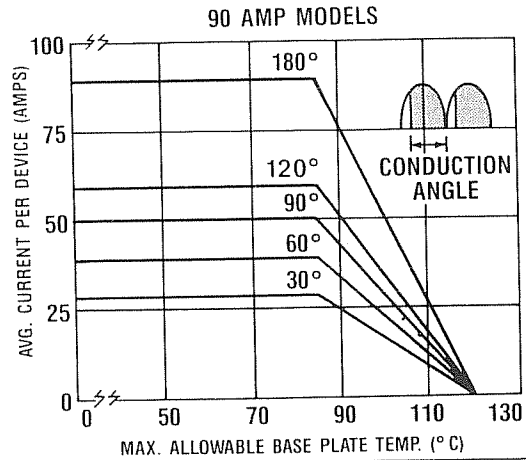
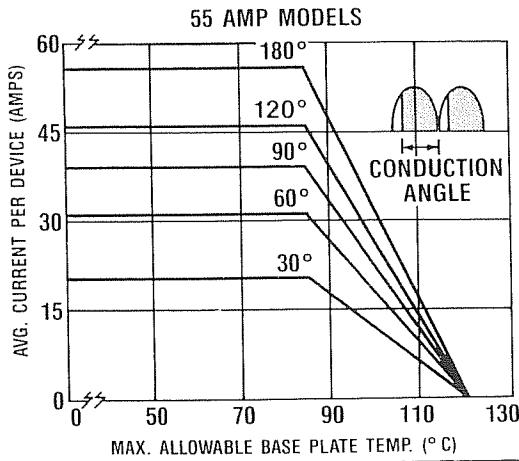
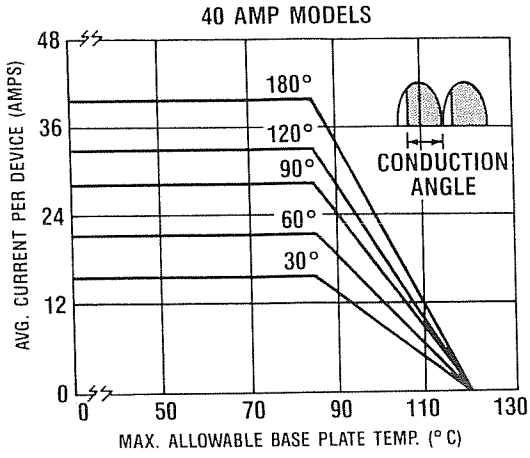
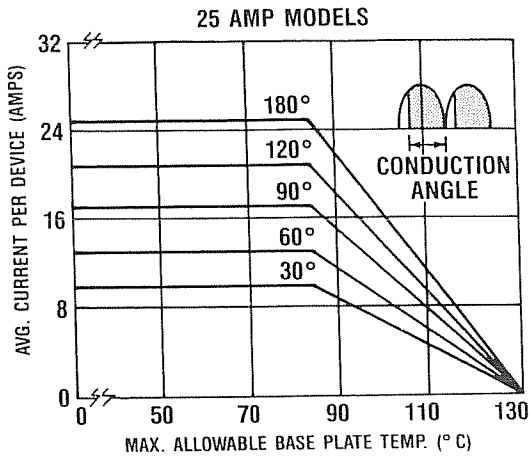

F18 SERIES AVERAGE ON-STATE POWER DISSIPATION VS. AVERAGE DEVICE CURRENT

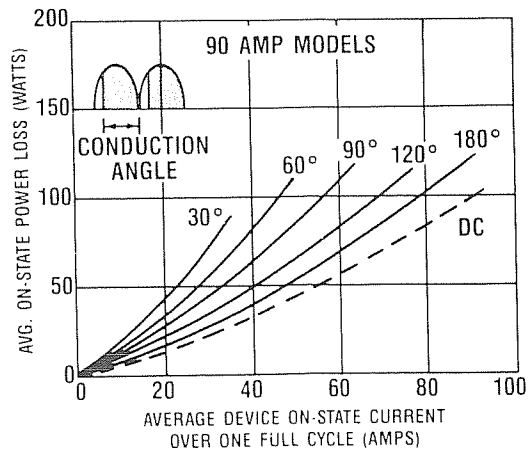
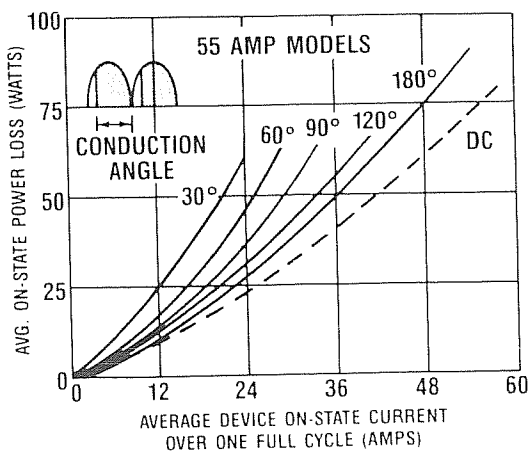
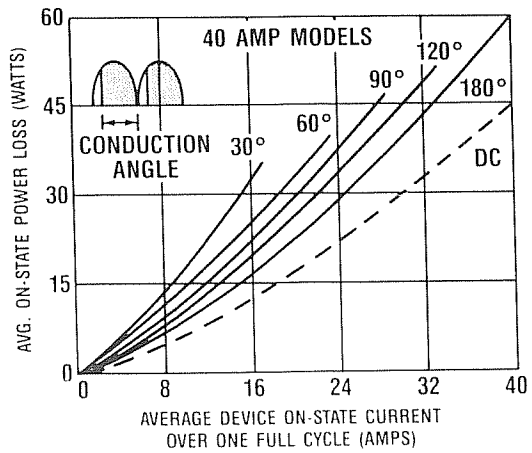
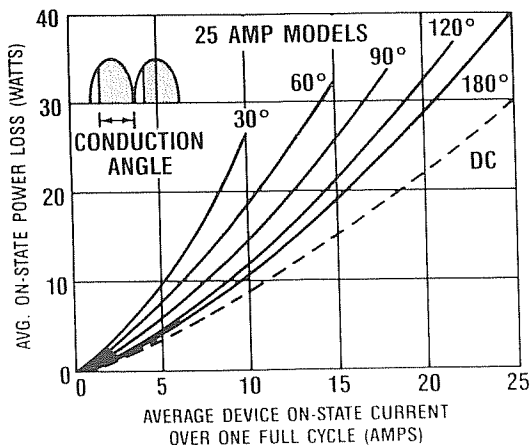

**F18 SERIES MAXIMUM INSTANTANEOUS ON-STATE VOLTAGE
VS. INSTANTANEOUS ON-STATE CURRENT**

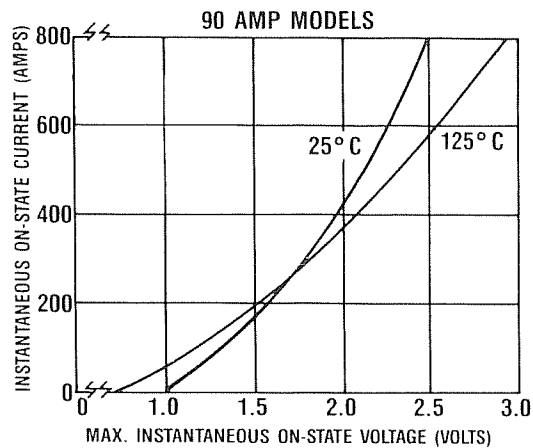
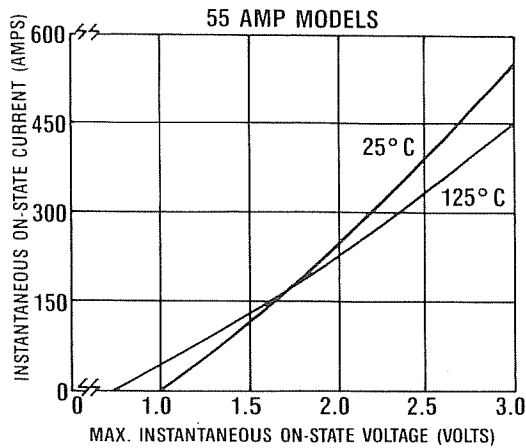
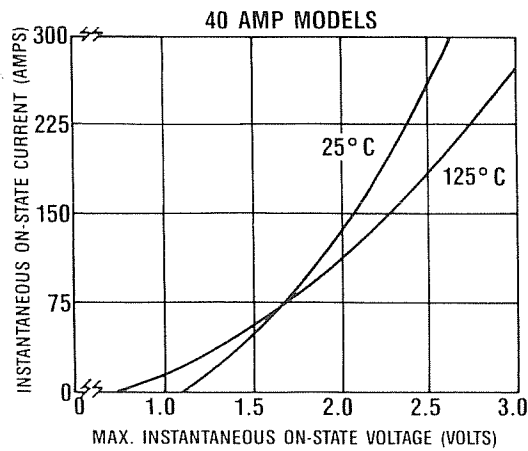
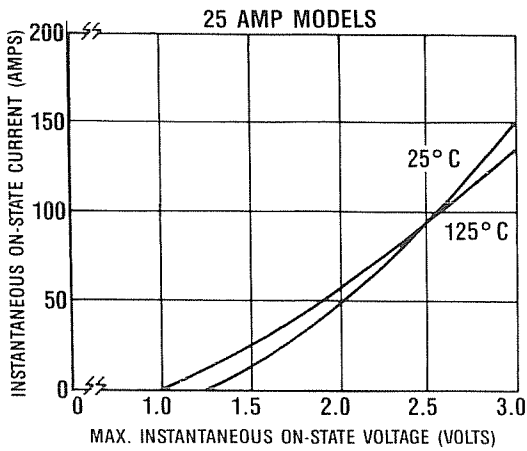

The characteristic curves shown are for each of the SCR elements (not for the total circuit). Diode element characteristic values are all equal to, or better than those shown for their companion SCR elements.

F18 SERIES GATE CHARACTERISTICS

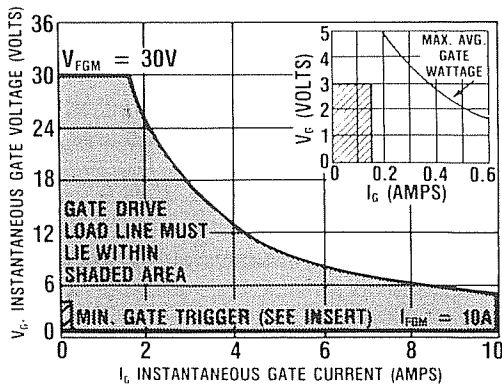

F18 SERIES MAXIMUM NON-REPETITIVE SURGE CURRENT

